



 UNION PROCESS[®]

CHOCOLATE AND COMPOUND COATING ATTRITORS



visit www.unionprocess.com

UNION PROCESS ATTRITOR TECHNOLOGY.

Attritor technology began as an idea developed by Dr. Andrew Szegvari. That idea grew to become the basis for Union Process, Inc. – and one of the most efficient grinding and dispersing technologies in the world.

Today, in addition to the chocolate and confectionary industries, Union Process Attritors are used in virtually every

industry including the chemical, agricultural, rubber, ceramic, paper coating, metal powder, pharmaceutical, and cosmetic industries.

Union Process Attritors are fast – up to ten times faster than conventional ball mills. They're safe, easy to use and maintain, require minimal space, are quiet and energy efficient with good temperature control. And Attritors produce fine, homogeneous dispersions with a very narrow particle size distribution.

CIRCULATION ATTRITORS

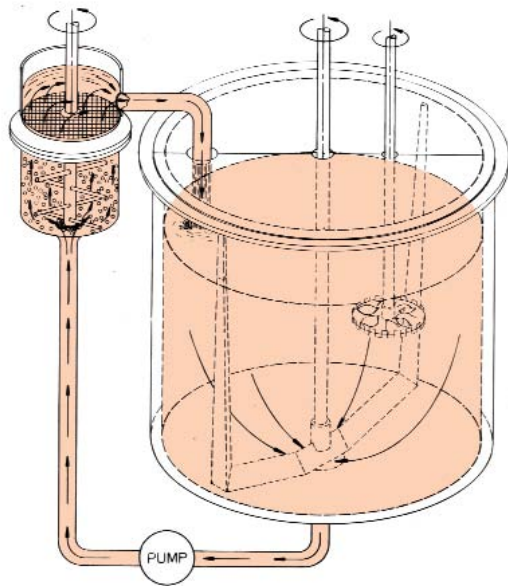

The circulation grinding Attritor ("Q" machine) is a combination of an Attritor, pump and a large holding tank about ten times the size of the Attritor. The Attritor is filled with media and contains grids which retain the media while the slurry is pumped through at a rapid rate.

The circulation Attritor rapidly pumps the material to be ground (slurry) through a confined bed of small agitated grinding media. The media acts as a dynamic sieve – the fine particles pass through easily, and the larger particles are ground more finely, resulting in a narrow particle size distribution. The slurry makes several passes through the Attritor until the desired particle size is reached. Additional ingredients can be added at any time and the slurry can be continuously monitored. Processing can be precisely terminated.

When the chocolate liquor has a high moisture content and/or high viscosity, the tank can be equipped with stationary arms, as an optional accessory, to prevent the entire charge from sliding.

The Circulation Attritor has the advantages of good temperature control due to the large, jacketed holding tank.



Q-50
ATTRITOR with
stationary arms.

*PASSAGE OF A SMALL & LARGE PARTICLE
THROUGH A LAYER OF AGITATED MEDIA*

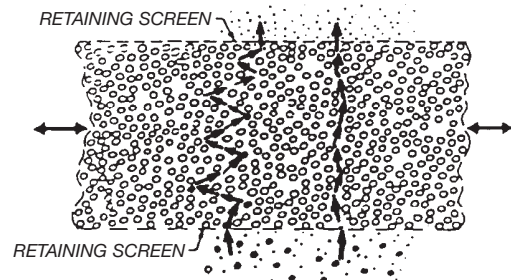

ATTRITOR ACTION

The operation of an Attritor is simple and effective. The material to be ground is placed in a stationary, jacketed tank with the grinding media. Carbon steel, stainless steel and chrome steel balls (3/16" or 1/4") are commonly used media. The material and media are then agitated by a rotating internal shaft with arms. The final result is a fine, even particle dispersion.

Attritors are produced in three types: circulation (Q-series), continuous (CH-series), and batch (S-series).



APPLICATIONS

- Cocoa liquors
- Dark or milk chocolate
- Confectionery compound coating
- Ice cream coatings
- Chocolate nut paste
- Nut dispersions
- Spice dispersions
- Cheese/oil dispersions

Q-25

Complete set-up with variable frequency drive motor

ADVANTAGES

- Features high pumping rates that result in faster grind and narrower particle size distribution.
- Easily grinds down to 20 microns – 10 microns.
- Reproducible results from batch to batch.
- Allows continuous monitoring of slurry and addition of ingredients to the premix tank at any time during the grinding.
- Low power consumption.
- Low maintenance with minimum down time.
- Has a jacketed grinding tank specially designed for temperature control. The holding tank is also jacketed for greater temperature control.

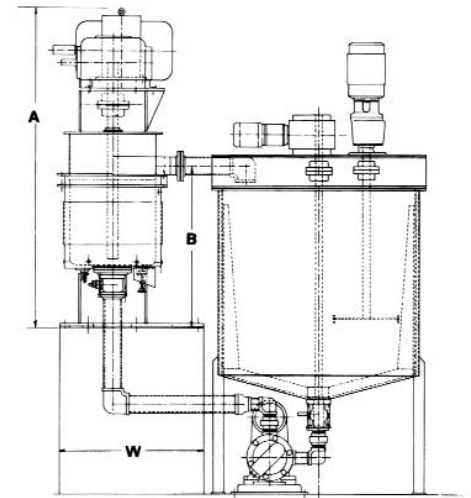

ENGINEERING DATA

ATTRITOR MODEL	Q-2	Q-6	Q-15	Q-25	Q-50	Q-100
Grinding Tank Capacity (gals.)	2.6	8.2	17	27.5	56	111
Media Volume (gals.)	2.2	7.5	15	25	50	100
Recommended Holding Tank Capacity (gals.)	5 or 10	75	150	250	500	1,000
HP	3-5	7.5-15	15-25	25-40	50-75	100-150
Pumping Rate* (gpm)	3.5	11	22	35	70	130
Total Height (A)	54"***	74"	86"	96"	120"	124"
Base to Discharge Spout (B)	-	32"	37"	43"	53"	59"
Floor Space (W x D)	26" x 50"***	33" x 46"	37" x 53"	41" x 60"	50" x 70"	63" x 78"
Weight (lbs.) w/o media	800**	1800	3000	4000	6500	9900

DIMENSIONS AND WEIGHTS ARE APPROXIMATE.
Circulation Attritors designated as "QL" include specially configured arms and disks.

*Pumping rate is somewhat lower with higher viscosity slurries.
**Dimensions and weights are for complete system.

The continuous Attritor system has a tall, narrow, jacketed tank into which a well premixed slurry is pumped through the bottom and discharged at the top. Grids located at both the top and bottom of the machine retain the media.

The tank is water jacketed to provide good temperature control.

The Attritor can optionally be fitted with stationary arms in the tank wall, in the configuration most suited for specific applications.

The continuous Attritor is designed to deliver hours of low cost, maintenance-free operation. The basic model features an open system that does not require an expensive shaft seal. In addition, grids separate the media from the discharge area and the discharge area is covered.



CH-22
Explosion-proof motor with remote variable frequency drive

CONTINUOUS ATTRITORS

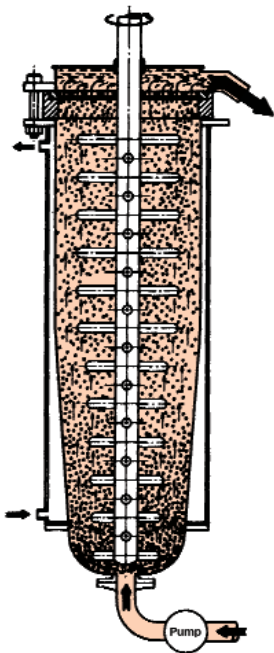

ADVANTAGES

- For continuous large production
- Single pass grinding and processing
- Excellent temperature control
- Simple and safe to operate
- Low maintenance
- Low power consumption
- Minimum floor space requirements

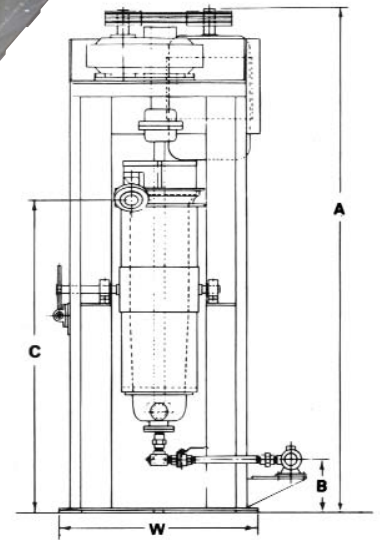

ENGINEERING DATA

ATTRITOR MODEL	CH-5	CH-11	CH-22	CH-44	CH-66	CH-110
Grinding Tank (gals)	6.0	14	27	49	79	133
Media Volume (gals)	5.5	11	22	44	66	110
HP	5 – 7.5	10 – 15	20 – 30	40 – 60	60 – 100	100 – 150
Total Height (A)	88"	104"	114"	129"	149"	166"
Intake Height (B)	12"	12"	17"	17"	17"	18"
Discharge Height (C)	48"	57"/54"	71"/72"	83"/81"	90"	96"/91"
Floor Space (W x D)	29" x 48"	50" x 40"	52" x 52"	58" x 60"	62" x 62"	66" x 66"
Weight (lbs) w/o media	1900	3600	4000	6500	9500	14,500

DIMENSIONS AND WEIGHTS ARE APPROXIMATE.

CHOCOLATE GRINDING PLANT

- For fine control of taste and flavor for cocoa liquor and confection formulations.
- Integrated system with automatic temperature control for heating and cooling.
- Heated pump, FDA-approved, stainless steel plumbing and transfer lines.
- Jacketed tanks to control temperature.
- Grinds down to 20 or 10 micron range.

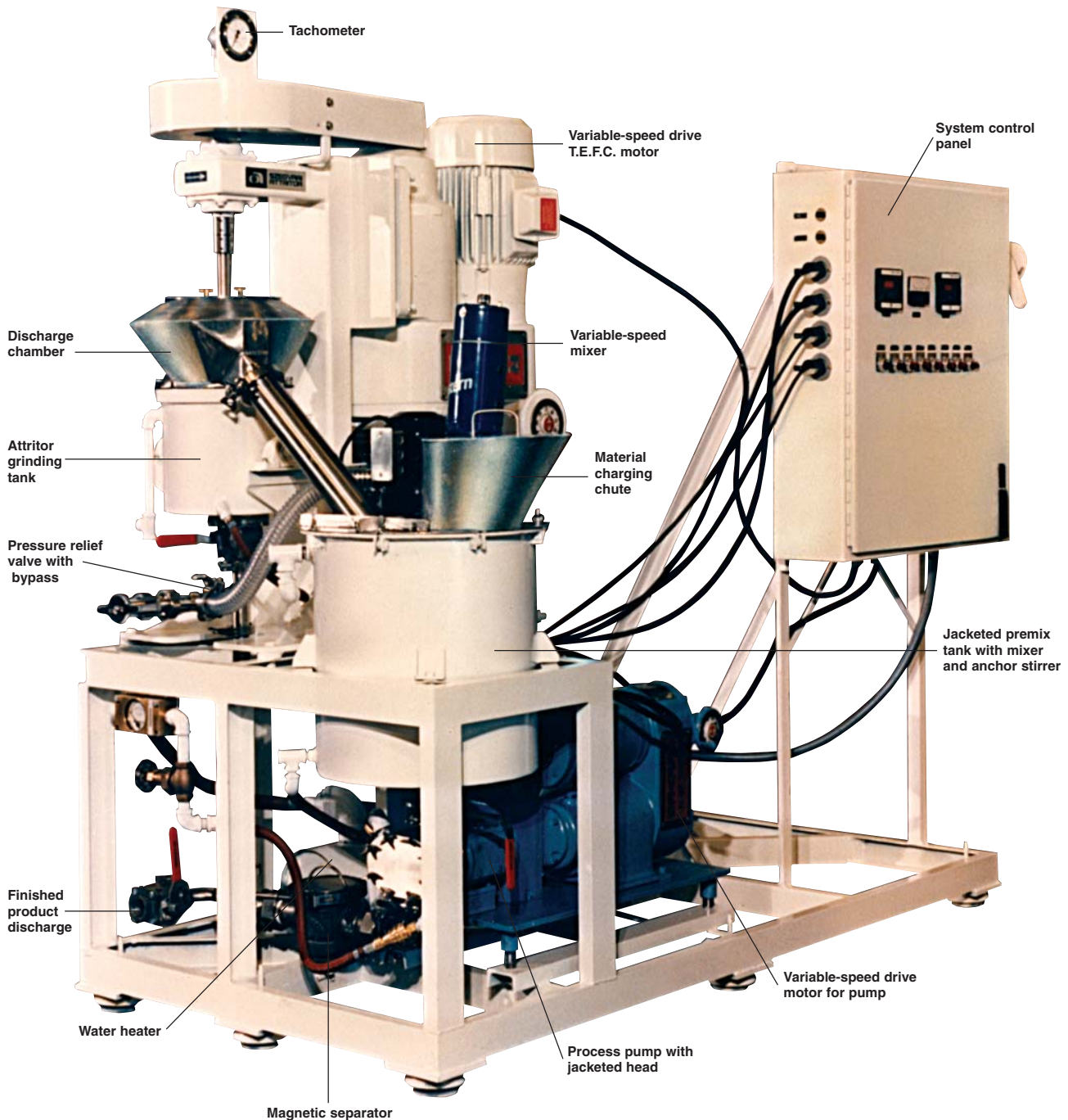

STANDARD FEATURES

All Attritors can be equipped with various accessories and custom designed to meet your specific needs.

The special 450% starting torque motor can be provided with different voltages such as 380 or 550, and with 50 cycles. Special "quiet" motors with 82 dba rating are also available.

Variable frequency drives are available for all machines. Besides providing the flexibility of variable shaft speeds, they also provide an LCD display of agitator RPM, motor AMPS, and motor HP being used.

Viking gear and Waukesha pumps are standard. Other pump types can be provided to meet special requirements.

PRODUCTION BATCH ATTRITORS

For very viscous applications such as chocolate and nut paste, the batch Attritor can be used. It has the advantage of allowing ingredients to be added directly to the grinding chamber without premixing. A pump can be supplied to aid in discharging the product from the grinding chamber. A gear tilting assembly facilitates easy removal of the agitator shaft for maintenance or cleaning of the grinding tank.



S-200

With remote variable frequency drive

GRINDING MEDIA

Union Process carries the highest quality chrome steel, carbon steel and stainless steel grinding media available.

TECHNICAL SUPPORT

We maintain an experienced staff of highly skilled technicians to assist you in meeting your chocolate grinding needs. You are welcome to attend a laboratory test run of your material, after which a complete lab report will be provided including all test data, processing recommendations and estimated production rates to meet your requirements.



01-HD

ATTRITOR with variable frequency drive



1-S

ATTRITOR with variable frequency drive

LABORATORY BATCH ATTRITORS

Batch Attritors are ideal for formulation research and studies where only a small quantity of test material is available or needed. Many accessories are available to meet various research criteria.

For complete information and specifications on Union Process laboratory Attritors, please request our Laboratory Grinding Mill brochure or download it from www.unionprocess.com/literature.html.

Some models have specially configured arms to enhance production. These units are designated with an "L" as in "30SL".

ENGINEERING DATA

ATTRITOR MODEL	S-5	S-10	S-15	S-30	S-50	S-100	S-200	S-400
Gross Tank Volume (gals)	9	16	24	52	81	155	309	597
Slurry Capacity (gals)	4-5	7-9	10-12	23-25	34-37	70-75	140-150	280-300
Media Volume (gals)	5	9	12	25	37	75	150	300
HP	3-5	5-7.5	5-10	10-20	15-25	20-40	40-75	75-150
Height*	79"	80"	83"	89"	97"	106"	121"	147"
Floor Space (W x D)	34" x 63"	52" x 42"	52" x 42"	61" x 43"	74" x 50"	82" x 56"	88" x 72"	108" x 80"
Machine Weight* (lbs) w/o media	1500	1800	2200	3100	3500	5000	8800	14,000

DIMENSIONS AND WEIGHTS ARE APPROXIMATE.

* Varies according to motor HP.



Union Process®

1925 Akron-Peninsula Road, Akron, Ohio 44313

Phone: (330) 929-3333 • Fax (330) 929-3034

Web: www.unionprocess.com

E-mail: unionprocess@unionprocess.com

Union Process, Inc. reserves the right to make improvements or change machine and equipment designs at any time without notice. Information contained herein is accurate to the best of our knowledge, but our suggestions and recommendations cannot be guaranteed because the conditions of use are beyond our control. Photos shown may include options that are not standard on that particular machine.

*Apparatus, Process and/or Product protected under one or more of the following U.S. Patents: 4,979,686; 5,080,293; 5,199,656; and other pending patent applications as well as corresponding and related foreign patent rights.™

© Registered trademark of Union Process, Inc. Form No. 905-5M

visit www.unionprocess.com